

PROXAM propose une gamme complète de produits pour la propulsion :

1. Hélices aluminium et hélices inox SOLAS, pour moteurs hors bord et embases Sterndrive : au total, une très large gamme du 5ch au 300ch, pour toute marque de moteurs. Les hélices aluminium sont classiques (AMITA à moyeu caoutchouc), ou à moyeu interchangeable (RUBEX à 3 ou 4 pales). Les hélices inox sont à moyeu caoutchouc interchangeable (RUBEX à partir de 60ch).
2. Hélices bronze, arbres d'hélice, coussinets, tourteaux, presse étoupes, joints PSS : pour voiliers et bateaux à moteur en ligne d'arbre.
3. Les produits proposés proviennent des plus grands constructeurs : SOLAS, OMM, PSS, etc...qui garantissent leur qualité. Les matériaux utilisés sont de première qualité (exemple des arbres d'hélice en 316L), et la technologie d'avant garde (par exemple : fabrication par injection des hélices SOLAS). Enfin, les solutions techniques sont souvent originales, comme les moyeux interchangeables en caoutchouc RUBEX.
4. Nouveauté : les hélices doubles Volvo DP, les hélices alu pour embases Merc. Bravo 2, les hélices alu/inox RUBEX à moyeu caoutchouc interchangeable.

Page 182 : hélices AMITA aluminium à moyeu caoutchouc de SOLAS

Page 186 : hélices doubles Volvo DP

Page 188 : hélices RUBEX alu/inox à moyeu interchangeable, en 3 ou 4 pales, de SOLAS

Page 190 : kits de montage d'hélices SOLAS : rondelle de butée, entretoise, etc...

Page 191 : joints tournants PSS

Page 192 : propulsion par ligne d'arbre :

- Arbres d'hélices inox
- Tourteaux
- Bagues hydrolubes
- Chaises, tube d'étambot
- Presse étoupes
- Gouvernails
- Chaises, etc...

 hélices aluminium, inox	 propulsion par ligne d'arbre
 joints tournants	

HÉLICES ALUMINIUM AMITA



TARIF 2009

euros

SOLAS

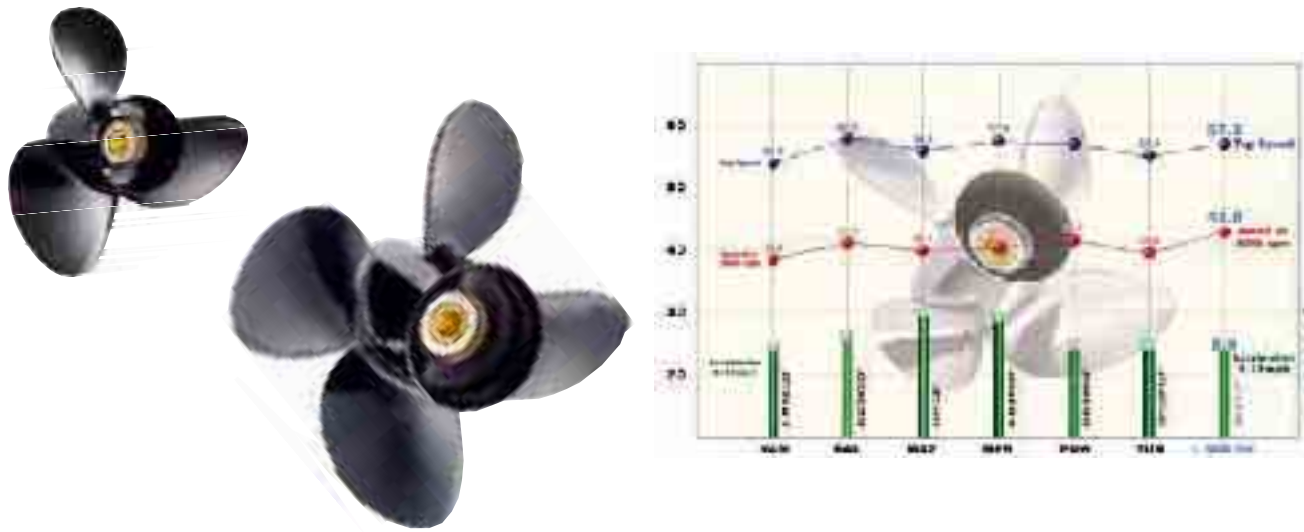

Les hélices AMITA sont les hélices à moyeu caoutchouc les plus résistantes du marché. A ce titre, la gamme AMITA représente la meilleure alternative aux hélices d'origine. L'étendue de la gamme est très large ; elle couvre tous les types de moteurs, et toutes les utilisations, des bateaux les plus lourds aux coques planantes les plus rapides.

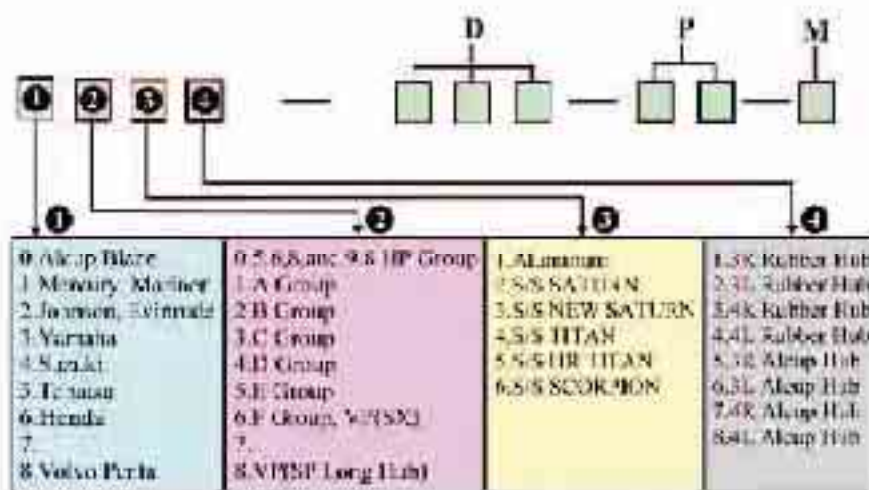

COMMENT SÉLECTIONNER UNE HÉLICE ?

Il faut éviter le surrégime moteur, tout en permettant au moteur d'atteindre le régime où la puissance maximale est fournie. Si un test permet au moteur de dépasser son régime maximal, il faut augmenter le pas de l'hélice. Une augmentation du pas de 2" entraînera une chute approximative du régime moteur de 300 à 400 tours/minute. Au contraire, une diminution du pas augmentera le régime moteur dans les mêmes proportions (300 à 400 tours/min pour 2" de pas).

JOHNSON / EVINRUDE 2T, OMC, SELVA 2T

moteurs	années	correspondance		nb pales	HELICE SOLAS AMITA					
		origine	Michigan		Ø x pas	rotation	référence			
9.9-15 (2T) 9.9-15 (4T)	74 & + 2000/01	High Thrust		4	10,00 x 7	RH	2113-100-07			
				3	9,25 x 8	RH	2111-093-08			
				3	9,25 x 9	RH	2111-093-09			
				3	9,25 x 10	RH	2111-093-10			
				moteur 4 temps à partir de 2002: voir suzuki						
20 2cyl. 25 2/3cyl. 30 2cyl. 35 2/3cyl.	84/97 84 & + 84 & + 76 & +			3	10,5 x 11	RH	2211-105-11			
				3	10,3 x 12	RH	2211-103-12			
				3	10,1 x 13	RH	2211-101-13			
				3	10,0 x 14	RH	2211-100-14			
moteur 4 temps: voir suzuki										
40 2cyl. 48 50-55 2cyl. 60 2cyl. 75 3cyl.	84 & + 87/96 75 & + 80/85 75/85			3	12,5 x 13	RH	2311-125-13			
				3	12,25 x 15	RH	2311-123-15			
				3	12,0 x 17	RH	2311-120-17			
				moteur 4 temps : voir suzuki						
				45-55Com 2cyl. 65Com 3cyl. 50-60-70-75 3cyl. 60-70 4T 85 à 140 40 à 90 E-Tec emb. 400/Cobra 4cyl.	80 & + 84 & + 75 & + 98 & + 70/96 2004 & +			3	14 x 11	RH
3	13,75 x 13	RH	2411-138-13							
3	13,5 x 15	RH	2411-135-15							
3	13,25 x 17	RH	2411-133-17							
3	13 x 19	RH	2411-130-19							
3	13 x 21	RH	2411-130-21							
moteur 4 temps 90 à 140ch: voir suzuki										
3	16 x 13	RH	2511-160-13							
3	15 x 15	RH	2511-150-15							
3	15 x 15	LH	2512-150-15							
90-115-130-140V4 150-175-185-200V6 225-235-250V6 250-275-300V8 200-225-250 E-Tec emb. 800/Cobra 15 cannelures	95 & + 78 & + 86 & + 86/95 2005 & +			3	15,8 x 15	RH	2511-158-15			
				3	14,8 x 17	RH	2511-148-17			
				3	14,8 x 17	LH	2512-148-17			
				3	14,5 x 19	RH	2511-145-19			
				3	14,5 x 19	LH	2512-145-19			
				3	14,3 x 21	RH	2511-143-21			
				3	14,3 x 21	LH	2512-143-21			
				3	14,2 x 23	RH	2511-142-23			
				3	14,2 x 23	LH	2512-142-23			
				SX 3.0L 4.3L 5.0L 5.7L 5.8L 7.4L 8.2L 19 Cannelures	94 & + 94 & + 94 & + 94 & + 94 & + 94/97 97 & + 97			3	15,5 x 13	RH
3	15 x 15	RH	8611-150-15							
3	15 x 15	LH	8612-150-15							
3	14,8 x 17	RH	8611-148-17							
3	14,8 x 17	LH	8612-148-17							
3	14,5 x 19	RH	8611-145-19							
3	14,5 x 19	LH	8612-145-19							
3	14,3 x 21	RH	8611-143-21							
3	14,3 x 21	LH	8612-143-21							

SOLAS

2111-093-08	75,21
2111-093-09	75,21
2111-093-10	75,21
2113-100-07	101,13
2211-100-14	92,06
2211-101-13	92,06
2211-103-12	92,06
2211-105-11	92,06
2311-120-17	123,70
2311-123-15	123,70
2311-125-13	123,70
2411-130-19	140,03
2411-130-21	140,03
2411-133-17	140,03
2411-135-15	140,03
2411-138-13	140,03
2411-140-11	140,03
2511-142-23	158,19
2511-143-21	158,19
2511-145-19	158,19
2511-148-17	158,19
2511-150-15	158,19
2511-158-15	158,19
2511-160-13	158,19
2512-142-23	158,19
2512-143-21	158,19
2512-145-19	158,19
2512-148-17	158,19
2512-150-15	158,19
8611-143-21	158,19
8611-145-19	158,19
8611-148-17	158,19
8611-150-15	158,19
8611-155-13	158,19
8612-143-21	158,19
8612-145-19	158,19
8612-148-17	158,19
8612-150-15	158,19



MERCURY



moteurs	années	HELICES SOLAS AMITA					
		correspondance origine	correspondance Michigan	nb pales	Ø x pas	rotation	référence
4				3	7,8 x 7	RH	1011-078-07
5				3	7,8 x 8	RH	1011-078-08
6-8-9.9 (2T)	86 & +	High Thrust		4	10,0 x 7	RH	1113-100-07
10	95 & +	48-828152A12	32056	3	9,25 x 7	RH	1111-093-07
15 (2/4T)	89 & +	48-828154A12	32054	3	9,25 x 8	RH	1111-093-08
9.9 (4T)	2002&+	48-828156A12	32052	3	9,25 x 9	RH	1111-093-09
		48-828158A12	32050	3	9,25 x 10	RH	1111-093-10
18	80/85	48-19636A10		3	11 x 9	RH	1211-110-09
20	86 & +	48-19638A40	31049	3	10,5 x 11	RH	1211-105-11
25 (2T)	86 & +			3	10,3 x 12	RH	1211-103-12
9.9-15 bigfoot (4T)	99 & +	48-19640A40	31048	3	10,1 X 13	RH	1211-101-13
		48-19642A40	31047	3	10,0 X 14	RH	1211-100-14
25 bigfoot (4T)	94 & +	48-73132A40	31015	3	12,1 x 9	RH	1311-121-09
30 (2/4T)	94 & +			3	12 x 10	RH	1311-120-10
35	84/89	48-816702A40	31056	3	11,6 x 11	RH	1311-116-11
40-50 (2/4T)	77 & +	48-816704A40	31057	3	11,4 x 12	RH	1311-114-12
55	95 & +	48-73136A40	31017	3	11,1 x 13	RH	1311-111-13
60-70 (2T)	84 & +	48-73138A40	31018	3	11,1 x 14	RH	1311-111-14
		48-73140A40	31019	3	11,0 x 15	RH	1311-110-15
60 bigfoot	95 & +			3	14 x 9	RH	1411-140-09
70	87 / 89	48-77338A40	31054	3	14 x 11	RH	1411-140-11
75 (2/4T)	84 & +	48-77340A40	31055	3	13,75 x 13	RH	1411-138-13
80	78 / 89	48-77342A40	31041	3	13,5 x 15	RH	1411-135-15
90-115 (2/4T)	78 & +	48-77344A40	31042	3	13,25 x 17	RH	1411-133-17
125	94 & +	48-77346A40	31043	3	13 x 19	RH	1411-130-19
		48-77348A40	31044	3	13 x 21	RH	1411-130-21
135	87 & +	48-78114A40	31022	3	16 x 13	RH	1511-160-13
150-175-200	78 & +	48-78116A40	31023	3	15 x 15	RH	1511-150-15
225	80 & +			3	15 x 15	LH	1512-150-15
250	94 & +	48-16440A40	31051	3	15,8 x 15	RH	1511-158-15
275-300	90 & +	48-832828A45	31024/64	3	14,8 x 17	RH	1511-148-17
DFI,EFI,Optimax				3	14,8 x 17	LH	1512-148-17
Alpha One		48-832830A45	31025/65	3	14,5 x 19	RH	1511-145-19
Bravo One				3	14,5 x 19	LH	1512-145-19
		48-78122A40	31026	3	14,3 x 21	RH	1511-143-21
		48-832834A45		3	14,3 x 21	LH	1512-143-21
				3	14,2 x 23	RH	1511-142-23
				3	14,2 x 23	LH	1512-142-23
Bravo 2				3	20x11	RH	1611-200-11
				3	20x11	LH	1612-200-11
				3	19,5x13	RH	1611-195-13
				3	19,5x13	LH	1612-195-13
				3	19,25x15	RH	1611-193-15
				3	19,25x15	LH	1612-193-15
				3	18,75x17	RH	1611-188-17
				3	18,75x17	LH	1612-188-17
				3	18,25x19	RH	1611-183-19
				3	18,25x19	LH	1612-183-19
				3	17,75x21	RH	1611-178-21
				3	17,75x21	LH	1612-178-21

SOLAS

1111-093-07	75,21
1111-093-08	75,21
1111-093-09	75,21
1111-093-10	75,21
1113-100-07	101,13
1211-100-14	92,30
1211-101-13	92,30
1211-103-12	92,30
1211-105-11	92,30
1211-110-09	92,06
1311-110-15	123,70
1311-111-13	123,70
1311-111-14	123,70
1311-114-12	123,70
1311-116-11	123,70
1311-120-10	123,70
1311-121-09	123,70
1411-130-19	140,03
1411-130-21	140,03
1411-133-17	140,03
1411-135-15	140,03
1411-138-13	140,03
1411-140-09	140,03
1411-140-11	140,03
1511-142-23	158,19
1511-143-21	158,19
1511-145-19	158,19
1511-148-17	158,19
1511-150-15	158,19
1511-158-15	158,19
1511-160-13	158,19
1512-142-23	158,19
1512-143-21	158,19
1512-145-19	158,19
1512-148-17	158,19
1512-150-15	158,19
1611-178-21	550,17
1611-183-19	550,17
1611-188-17	550,17
1611-193-15	550,17
1611-195-13	550,17
1611-200-11	550,17
1612-178-21	550,17
1612-183-19	550,17
1612-188-17	550,17
1612-193-15	550,17
1612-195-13	550,17
1612-200-11	550,17

HÉLICES ALUMINIUM AMITA



TARIF 2009

euros

HONDA

Moteurs	années	correspondance		nb pales	HELICES SOLAS AMITA		
		origine	Michigan		Ø x Pas	rotation	référence
8 9.9-15 20	2001 & + 88 & + 2003 & +	<i>high thrust</i>	112004	4	10,0 x 7	RH	3113-100-07
				3	9,25 x 7	RH	3111-093-07
			102003	3	9,25 x 8	RH	3111-093-08
		58130-ZV4-701ZA	102004	3	9,25 x 9	RH	3111-093-09
		58130-ZV4-030ZA	102005	3	9,25 x 10	RH	3111-093-10
25 30	Toutes années	58130-ZV7-860ZB	142020	3	9,9 x 9	RH	5211-099-09
		58130-ZV7-850A	142022	3	9,9 x 10	RH	5211-099-10
		58130-ZV7-000ZA		3	9,9 x 11	RH	5211-099-11
			142024	3	9,9 x 12	RH	5211-099-12
				3	9,9 x 13	RH	5211-099-13
35 40 45 50	91/94 95 & + 91/94 95 & +	58130-ZV5-860ZA	32045	3	12,1 x 9	RH	3311-121-09
				3	12 x 10	RH	3311-120-10
			32044	3	11,6 x 11	RH	3311-116-11
		58130-ZV5-850ZA	32043	3	11,4 x 12	RH	3311-114-12
		58130-ZV5-000ZA	32042	3	11,1 x 13	RH	3311-111-13
			32041	3	11,1 x 14	RH	3311-111-14
		58130-ZV5-870ZA	32040	3	11,0 x 15	RH	3311-110-15
75 90 115 130	95 & + 95 & + 98 & + 98 & +	58130-ZW1-W01ZA	31054	3	14 x 9	RH	1411-140-09
		58130-ZW1-W11ZA	31055	3	14 x 11	RH	1411-140-11
		58130-ZW1-W11ZA	31055	3	13,75 x 13	RH	1411-138-13
		58130-ZW1-W21ZA	31041	3	13,5 x 15	RH	1411-135-15
		58130-ZW1-W31ZA	31042	3	13,25 x 17	RH	1411-133-17
		58130-ZW1-W61ZA	31043	3	13 x 19	RH	1411-130-19
		58130-ZW1-W41ZA	31044	3	13 x 21	RH	1411-130-21
135 150 200 225	2004 & + 2004 & + 2002 & + 2002 & +		31022	3	16 x 13	RH	1511-160-13
			31023	3	15 x 15	RH	1511-150-15
				3	15 x 15	LH	1512-150-15
			31051	3	15,8 x 15	RH	1511-158-15
			31024/64	3	14,8 x 17	RH	1511-148-17
				3	14,8 x 17	LH	1512-148-17
			31025/65	3	14,5 x 19	RH	1511-145-19
				3	14,5 x 19	LH	1512-145-19
			31026	3	14,3 x 21	RH	1511-143-21
				3	14,3 x 21	LH	1512-143-21
				3	14,2 x 23	RH	1511-142-23
		3	14,2 x 23	LH	1512-142-23		

TOHATSU

moteurs	années	correspondance		nb pales	HELICES SOLAS AMITA		
		origine	Michigan		dia x pas	rotation	référence
8 9,8				3	8,50 x 7	RH	5011-085-07
				3	8,50 x 8	RH	5011-085-08
				3	8,50 x 9	RH	5011-085-09
9.9 12 15 18	85/00 85/88 84/00 85/00	<i>high thrust</i>		4	10,0 x 7	RH	5113-100-07
		362-64105-0	142015	3	9,25 x 8	RH	5111-093-08
		362-64102-0	142017	3	9,25 x 9	RH	5111-093-09
		362-64108-0	142019	3	9,25 x 10	RH	5111-093-10
9.9-15-18 (4T) 25 30 25-30 (4T)	2001 & + 86/01 85/01 2002 & +	346-64106-5	142020	3	9,9 x 9	RH	5211-099-09
		346-64102-5	142022	3	9,9 x 10	RH	5211-099-10
				3	9,9 x 11	RH	5211-099-11
		346-64104-5	142024	3	9,9 x 12	RH	5211-099-12
				3	9,9 x 13	RH	5211-099-13
35 40 50 55 60 70	jusq.84 84 & + 87 & + 81/88 86/98 81/98	361-64113-0	142001	3	12,1 x 9	RH	5311-121-09
		361-64114-0	142002	3	11,6 x 11	RH	5311-116-11
		348-64102-0	142003	3	11,4 x 12	RH	5311-114-12
		348-64103-0	142004	3	11,1 x 13	RH	5311-111-13
				3	11,1 x 14	RH	5311-111-14
				3	11,0 x 15	RH	5311-110-15
60 70 90 115 120 140	99 & + 99 & + 87 & + 86 & + 88 & +			3	14 x 9	RH	3411-140-09
				3	14 x 11	RH	3411-140-11
		3B7-64532-0	142010	3	13,75 x 13	RH	3411-138-13
		3B7-64536-0	142011	3	13,5 x 15	RH	3411-135-15
		3B7-64541-0	142012	3	13,25 x 17	RH	3411-133-17
		3B7-64545-0	142013	3	13 x 19	RH	3411-130-19
		3	13 x 21	RH	3411-130-21		

SOLAS

1411-130-19	140,03
1411-130-21	140,03
1411-133-17	140,03
1411-135-15	140,03
1411-138-13	140,03
1411-140-09	140,03
1411-140-11	140,03
1511-143-21	158,19
1511-145-19	158,19
1511-148-17	158,19
1511-150-15	158,19
1511-158-15	158,19
1511-160-13	158,19
1512-145-19	158,19
1512-148-17	158,19
1512-150-15	158,19
3111-093-07	75,21
3111-093-08	75,21
3111-093-09	75,21
3111-093-10	75,21
3113-100-07	101,13
3311-110-15	123,70
3311-111-13	123,70
3311-111-14	123,70
3311-114-12	123,70
3311-116-11	123,70
3311-120-10	127,40
3311-121-09	123,70
3411-130-19	140,03
3411-130-21	140,03
3411-133-17	140,03
3411-135-15	140,03
3411-138-13	140,03
3411-140-09	140,03
3411-140-11	140,03
5011-085-07	75,21
5011-085-08	75,21
5011-085-09	75,21
5111-093-08	75,21
5111-093-09	75,21
5111-093-10	75,21
5113-100-07	101,13
5211-099-09	92,06
5211-099-10	92,06
5211-099-11	92,06
5211-099-12	92,06
5211-099-13	92,06
5311-110-15	123,70
5311-111-13	123,70
5311-111-14	123,70
5311-114-12	123,70
5311-116-11	123,70
5311-121-09	123,70

SOLAS

3413-138-15	154,03
3413-138-17	154,03
3413-138-19	154,03
3413-138-21	154,03
4111-093-08	75,21
4111-093-09	75,21
4111-093-10	75,21
4211-100-14	92,06
4211-101-13	92,06
4211-103-12	92,06
4211-105-11	92,06
4311-116-12	127,40
4311-116-13	127,40
4311-116-14	127,40
4311-118-11	127,40
4311-120-10	127,40
4411-130-19	140,03
4411-130-21	140,03
4411-133-17	140,03
4411-135-15	140,03
4411-138-13	140,03
4411-140-11	140,03
4511-142-23	158,19
4511-143-21	158,19
4511-145-19	158,19
4511-148-17	158,19
4511-150-15	158,19
4512-142-23	158,19
4512-143-21	158,19
4512-145-19	158,19
4512-148-17	158,19
4512-150-15	158,19
8611-143-21	158,19
8611-145-19	158,19
8611-148-17	158,19
8611-150-15	158,19
8611-155-13	158,19
8612-143-21	158,19
8612-145-19	158,19
8612-148-17	158,19
8612-150-15	158,19
JEU3	426,06
JEU4	426,06
JEU5	426,06
JEU6	426,06
KIT3	426,06
KIT3-1	426,06
KIT4	426,06
KIT4-1	426,06
KIT5	426,06
KIT6	426,06
KIT7	426,06

SUZUKI

moteurs	années	correspondance		nb pales	HELICES SOLAS AMITA		
		origine	Michigan		dia x pas	rotation	référence
DT9.9	83/87	58100-93703-019	62015	3	9,25 x 8	RH	4111-093-08
DT15-15C	83/97	58100-93723-019	62016	3	9,25 x 9	RH	4111-093-09
DF9.9-15 (4T)	97 & +	58100-93743-019	62017	3	9,25 x 10	RH	4111-093-10
DT20	83/88	58100-96420-019	62012	3	10,5 x 11	RH	4211-105-11
DT25-25C	83/00	58100-96430-019	62013	3	10,3 x 12	RH	4211-103-12
DT30-30C	83/97	58100-96440-019	62014	3	10,1 x 13	RH	4211-101-13
DF25-30 (4T)	2000 & +			3	10,0x 14	RH	4211-100-14
DT40	83/98			3	12 x 10	RH	4311-120-10
DT50-50M	83/84	58100-95222-019	32044	3	11.8 x 11	RH	4311-118-11
DT55	88/97	58100-95393-019	32043	3	11.6 x 12	RH	4311-116-12
DT60	83/84	58100-95313-019	32042	3	11.6 x 13	RH	4311-116-13
DT65	85/97	58100-95353-019	32041	3	11.6 x 14	RH	4311-116-14
DF40-50 (4T)	99 & +						
DT75	83/97			3	14 x 11	RH	4411-140-11
DT85	88/00			3	13,75 x 13	RH	4411-138-13
DT90	89/97	58100-95500-019	61001	3	13,5 x 15	RH	4411-135-15
DT115-140	83/01	58100-95511-019	61002	3	13,25 x 17	RH	4411-133-17
DF60-70 (4T)	98 & +	58100-95521-019	61003	3	13 x 19	RH	4411-130-19
		58100-95530-019	61004	3	13 x 21	RH	4411-130-21
DF90 (4T)	2001 & +			4	13,75 x 15	RH	3413-138-15
DF115 (4T)	2001 & +			4	13,75 x 17	RH	3413-138-17
DF140 (4T)	2001 & +			4	13,75 x 19	RH	3413-138-19
				4	13,75 x 21	RH	3413-138-21
DT150	86 & +			3	15 x 15	RH	4511-150-15
DT200	86 & +			3	15 x 15	LH	4512-150-15
DT225	86 & +			3	14.8 x 17	RH	4511-148-17
DF200				3	14.8 x 17	LH	4512-148-17
DF225				3	14.5 x 19	RH	4511-145-19
DF250				3	14.5 x 19	LH	4512-145-19
				3	14.3 x 21	RH	4511-143-21
				3	14,3 x 21	LH	4512-143-21
				3	14,2 x 23	RH	4511-142-23
				3	14,2 x 23	LH	4512-142-23

VOLVO SX

moteurs	années	correspondance		nb pales	HELICES SOLAS AMITA		
		origine	Michigan		Ø x pas	rotation	référence
SX	94 & +			3	15,5 x 13	RH	8611-155-13
3.0L	94 & +	3850299-3	161001	3	15 x15	RH	8611-150-15
4.3L	94 & +			3	15 x 15	LH	8612-150-15
5.0L	94 & +	3850300-9	161002	3	14,8 x 17	RH	8611-148-17
5.7L	94 & +			3	14,8 x 17	LH	8612-148-17
5.8L	94/97	3850301-7	161003	3	14,5 x 19	RH	8611-145-19
7.4L	97 & +			3	14,5 x 19	LH	8612-145-19
8.2L	97	3850302-5	161004	3	14,3 x 21	RH	8611-143-21
				3	14,3 x 21	LH	8612-143-21

HELICES VOLVO DUO PROP

type Volvo	hélice AV 3 pales	hélice AR 4 pales	réf.
B3	15,5x17LB	13,75x17RB	JEU3
A3	15,5x17LB	13,75x19RB	KIT3
A3	15,3x19LB	13,75x19RB	KIT3-1
B4	15,3x19LB	13,75x19RB	JEU4
A4	15,3x19LB	13,75x19RB	KIT4
A4	15,3x19LB	13,75x21RB	KIT4-1
B5	15,3x19LB	13,75x21RB	JEU5
A5	15,3x19LB	13,75x21RB	KIT5
A6	15,3x21LB	13,75x21RB	KIT6
B6	15,3x21LB	13,75x21RB	JEU6
A7	15,3x21LB	13,75x21RB	KIT7



SOLAS

3011-085-07	75,21
3011-085-08	75,21
3011-085-09	75,21
3111-093-07	75,21
3111-093-08	75,21
3111-093-09	75,21
3111-093-10	75,21
3113-100-07	101,13
3211-099-09	92,06
3211-099-10	92,06
3211-099-11	92,06
3211-099-12	92,06
3211-099-13	92,06
3311-110-15	123,70
3311-111-13	123,70
3311-111-14	123,70
3311-114-12	123,70
3311-116-11	123,70
3311-120-10	123,70
3311-121-09	123,70
3411-130-19	140,03
3411-130-21	140,03
3411-133-17	140,03
3411-135-15	140,03
3411-138-13	140,03
3411-140-09	140,03
3411-140-11	140,03
3411-140-13	140,03
3511-142-23	158,19
3511-143-21	158,19
3511-145-19	158,19
3511-148-17	158,19
3511-150-15	158,19
3511-158-15	158,19
3511-160-13	158,19
3512-142-23	158,19
3512-143-21	158,19
3512-145-19	158,19
3512-148-17	158,19
3512-150-15	158,19

YAMAHA 2T/4T, SELVA 4T

moteurs	années	correspondance		nb pales	HELICES SOLAS AMITA		
		origine	Michigan		Ø x pas	rotation	référence
6 8	86&+	6G1-45947-00-EL	102001	3	8,5 x 7	RH	3011-085-07
	86&+	6G1-45943-00-EL	102002	3	8,5 x 8	RH	3011-085-08
			102013	3	8,5 x 9	RH	3011-085-09
9,9 15 F15 (4T)	84 & +	<i>high thrust</i>		4	10,0 x 7	RH	3113-100-07
	86 & +			3	9,25 X 7	RH	3111-093-07
	2000 & +	683-45947-00-EL	102003	3	9,25 x 8	RH	3111-093-08
		683-45945-00-EL	102004	3	9,25 x 9	RH	3111-093-09
20 25 30 F25 (4T) F30 (4T)	96/97	664-45941-01-EL	22001	3	9,9 x 9	RH	3211-099-09
	80 & +	664-45945-01-EL	22002	3	9,9 x 10	RH	3211-099-10
	79 & +	664-45947-01-EL	102015	3	9,9 x 11	RH	3211-099-11
	2000 & +	664-45954-00-EL	22003	3	9,9 x 12	RH	3211-099-12
	2001 & +			3	9,9 x 13	RH	3211-099-13
40 48 50 55 60 F30-F40 (4T) F50-F60 (4T)	84 & +	663-45956-01-EL	102016	3	12,1 x 9	RH	3311-121-09
	95 & +			3	12 x 10	RH	3311-120-10
	84 & +	663-45947-02-EL	32044	3	11,6 x 11	RH	3311-116-11
	76/95	6H5-45952-00-EL	32043	3	11,4 x 12	RH	3311-114-12
	76/91	6H5-45945-00-EL	32042	3	11,1 x 13	RH	3311-111-13
	99 & +	663-45958-01-EL	32041	3	11,1 x 14	RH	3311-111-14
	99 & +	6H5-45943-00-EL	32040	3	11,0 x 15	RH	3311-110-15
T50-T60 (4T) 60 70 75 80 85 90-115-130 F75-F80-F100 (4T) F115 (4T)	96 & +			3	14 x 9	RH	3411-140-09
	92 & +	6E5-45954-00-EL	101036	3	14 x 11	RH	3411-140-11
	84 & +	6E5-45949-00-EL	101031	3	13,75 x 13	RH	3411-138-13
	94 & +	6E5-45947-00-EL	101032	3	13,5 x 15	RH	3411-135-15
	78/89	6E5-45945-01-EL	101033	3	13,25 x 17	RH	3411-133-17
	91/97	6E5-45941-00-EL	101034	3	13 x 19	RH	3411-130-19
	84 & +	6E5-45943-00-EL	101035	3	13 x 21	RH	3411-130-21
150 175-200 220 225 250-300 F150-F200 (4T) F225-F250 (4T) Sterndrive	86 & +			3	16 x 13	RH	3511-160-13
	84 & +	6G5-45941-00-98	101025	3	15 x 15	RH	3511-150-15
	87/88			3	15 x 15	LH	3512-150-15
	80 & +			3	15,8 x 15	RH	3511-158-15
	90 & +	6G5-45947-01-98	101027	3	14,8 x 17	RH	3511-148-17
	2002 & +			3	14,8 x 17	LH	3512-148-17
	2003 & +	6G5-45945-01-98	101028	3	14,5 x 19	RH	3511-145-19
				3	14,5 x 19	LH	3512-145-19
		6H5-45943-01-98	101029	3	14,3 x 21	RH	3511-143-21
				3	14,3 x 21	LH	3512-143-21
	6G5-45949-00-98		3	14,2 x 23	RH	3511-142-23	
			3	14,2 x 23	LH	3512-142-23	



HELICES ALUMINIUM RUBEX SANS MOYEU

RUBEX ALU 3 pales (groupe D : 60-140ch)				
nb.pales	dia	pas	rot.	réf.
3	13,75	13	R	9411-138-13
3	13,5	15	R	9411-135-15
3	13,25	17	R	9411-133-17
3	13,2	19	R	9411-132-19

RUBEX ALU 4 pales (groupe D : 60-140ch)				
nb.pales	dia.	pas	rot.	réf.
4	13,25	13	R	9413-133-13
4	13	15	R	9413-130-15
4	12,75	17	R	9413-128-17
4	12,5	19	R	9413-125-19

RUBEX ALU 3 pales (groupe E : 150-300ch + sterndrive)				
nb.pales	dia	pas	rot.	réf.
3	15	15	R	9511-150-15
3	14,8	17	R	9511-148-17
3	14,5	19	R	9511-145-19
3	14,3	21	R	9511-143-21

RUBEX ALU 4 pales (groupe E : 150-300ch + sterndrive)				
nb.pales	dia.	pas	rot.	réf.
4	14,75	15	R	9513-148-15
4	14,5	17	R	9513-145-17
4	14,25	19	R	9513-143-19
4	14	21	R	9513-140-21

MOYEU RUBEX POUR HELICES ALU/INOX

marque	désignation	réf.	groupe
EVINRUDE JOHNSON BRP	45-75ch gros pied (1968&+) 13 cannelures	RBX-106	D
	85-140ch (1969&+) 13 cannelures	RBX-106	D
	60-70ch 4T (1998&+) 13 cannelures	RBX-110	D
	90, 115ch 4T (2003&+) 15 cannelures	RBX-125	D
	140ch 4T (2003&+) 15 cannelures	RBX-126	D
	90-140ch gros pied (1976-90) 15 cannelures	RBX-101	E
	90-140ch gros pied (1991&+) 15 cannelures	RBX-100	E
FORCE	75-150ch (1995&+) 15 cannelures	RBX-102	D
HONDA	BF75-90ch (1995-98) 15 cannelures	RBX-102	D
	BF75-90ch (1999&+), 115-130ch (1998&+) 15 cannelures	RBX-107	D
	BF135, 150, 200, 225ch (2003&+) 15 cannelures	RBX-107	E
MERCURY/MARINER/ MERCUISER	60ch Bigfoot, 70-140ch (sauf 135) (1961&+) XR-4/6 15 cannelures	RBX-102	D
	150-300ch (1978&+), Alpha et Bravo One 15 cannelures	RBX-102	E
	225 EFI 4T origine Yamaha	RBX-124	E
TOHATSU	90-140ch (1987&+) 15 cannelures	RBX-109	D
OMC	embases 400/Cobra (1978-91) 13 cannelures	RBX-106	D
	embases 800/Cobra/King Cobra (1978-90) 15 cannelures	RBX-101	E
	embases 800/Cobra/King Cobra (1991-94) 15 cannelures	RBX-100	E
	Cobra SX (1994&+) 19 cannelures	RBX-105	E
SUZUKI	DF90, DF115 4T (2001&+) 15 cannelures	RBX-125	D
	DF140 4T (2001&+) 15 cannelures	RBX-126	D
	75-140ch, DF60, DF70 (1979&+) 13 cannelures	RBX-110	D
	DT150-225ch 2T (1986&+), DF150-300ch 4T 13 cannelures	RBX-104	E
YAMAHA	60-100ch yc 4T (1984&+), T50 (1996+) 15 cannelures	RBX-108	D
	80-140ch (1978-83) 15 cannelures	RBX-102	D
	115ch, F115/130ch 4T (1984&+) 15 cannelures	RBX-103	D
	150-175ch (1978-83) 15 cannelures	RBX-102	E
	150-300ch (1984&+), sterndrive (1989-93) 15 cannelures	RBX-103	E
225 EFI 4T	RBX-124	E	
VOLVO SX	embases SX (1994&+) 19 cannelures	RBX-105	E

SOLAS

9411-132-19	102,78
9411-133-17	102,78
9411-135-15	102,78
9411-138-13	102,78
9413-125-19	113,04
9413-128-17	113,04
9413-130-15	113,04
9413-133-13	113,04
9431-130-19	325,65
9431-130-21	325,65
9431-133-17	325,65
9431-135-15	325,65
9431-138-13	325,65
9432-130-19	325,65
9432-133-17	325,65
9432-135-15	325,65
9432-138-13	325,65
9511-143-21	115,48
9511-145-19	115,48
9511-148-17	115,48
9511-150-15	115,48
9513-140-21	127,02
9513-143-19	127,02
9513-145-17	127,02
9513-148-15	127,02
9531-140-19	334,89
9531-140-21	334,89
9531-140-23	334,89
9531-143-17	334,89
9531-145-15	334,89
9532-140-19	334,89
9532-140-21	334,89
9532-140-23	334,89
9532-143-17	334,89
9532-145-15	334,89
9553-140-21	360,33
9553-140-23	360,33
9553-141-19	360,33
9553-143-17	360,33
9553-145-15	360,33
9554-140-21	360,33
9554-140-23	360,33
9554-141-19	360,33
9554-143-17	360,33
9554-145-15	360,33
RBX-100	42,73
RBX-101	42,73
RBX-102	42,73
RBX-103	42,73
RBX-104	42,73
RBX-105	42,73
RBX-106	42,73
RBX-107	42,73
RBX-108	42,73
RBX-109	42,73
RBX-110	42,73
RBX-124	42,73
RBX-125	42,73
RBX-126	42,73

HELICES INOX RUBEX SANS MOYEU

RUBEX NS3 3 pales (groupe D : 60-140ch)				
nb.pales	dia.(pouces)	pas (pouces)	rot.	réf.
3	13 3/4	13	R	9431-138-13
3	13 3/4	13	L	9432-138-13
3	13 1/2	15	R	9431-135-15
3	13 1/2	15	L	9432-135-15
3	13 1/4	17	R	9431-133-17
3	13 1/4	17	L	9432-133-17
3	13	19	R	9431-130-19
3	13	19	L	9432-130-19
3	13	21	R	9431-130-21

RUBEX NS3/HR4 3 et 4 pales (groupe E : 150-300ch + sterndrive)					
pas		Dia.	réf. 3 pales	Dia.	réf. 4 pales
15	R	14,5	9531-145-15	14,5	9553-145-15
15	L	14,5	9532-145-15	14,5	9554-145-15
17	R	14,25	9531-143-17	14,25	9553-143-17
17	L	14,25	9532-143-17	14,25	9554-143-17
19	R	14	9531-140-19	14,125	9553-141-19
19	L	14	9532-140-19	14,125	9554-141-19
21	R	14	9531-140-21	14	9553-140-21
21	L	14	9532-140-21	14	9554-140-21
23	R	14	9531-140-23	14	9553-140-23
23	L	14	9532-140-23	14	9554-140-23

HÉLICES ALUMINIUM À MOYEU INTERCHANGEABLE

Moyeu caoutchouc Haute Performance SOLAS
Interchangeable avec les hélices Flo-Torque et Vortex
Important : un moyeu RUBEX est nécessaire pour chaque montage, Brevets déposés aux USA et en Europe



Moyeu à commander séparément.



PROCEDES DE FABRICATION EXCLUSIFS SOLAS

1. Les hélices aluminium SOLAS sont INJECTEES sous pression : profil de pale affiné, résistance diminuée,
2. Les hélices aluminium SOLAS sont protégées par une couche de protection, une couche de primaire, 2 couches de finition,

HÉLICES INOX À MOYEU INTERCHANGEABLE

Moyeu caoutchouc Haute Performance SOLAS
Interchangeable avec les hélices Flo-Torque et Vortex
Important : un moyeu RUBEX est nécessaire pour chaque montage, Brevets déposés aux USA et en Europe



Moyeu à commander séparément.



PROCEDES DE FABRICATION EXCLUSIFS SOLAS

1. Les hélices inox SOLAS sont INJECTEES sous pression : profil de pale affiné, résistance diminuée,
2. Les hélices inox SOLAS sont fabriquées en alliage 24-10, comparé à l'alliage 15-5 des autres marques : meilleures performances, meilleure protection anti-corrosion.



KITS DE MONTAGE D'HÉLICES



TARIF 2009

euros

SOLAS

APIN	1,19
CPIN	2,00
EPIN	2,00
MANT	0,99
MBNT	2,96
MCNT	5,67
MCTW	11,12
MCWS	1,95
MDNT	6,28
MESP	5,92
METW	15,81
MEWS	4,15
OANT	2,18
OASP	2,11
OATW	10,92
OBNT	5,54
OBSP	3,57
OBTW	12,29
OCNT	6,23
OCSP	2,98
OCTW	29,17
ODTW	24,73
OENT	7,00
OESP	10,02
OETW	17,38
SANT	2,26
SBNT	2,26
TANT	2,26
TATW	5,25
TBTW	10,88
TCNT	5,92
TCTW	17,78
TDTW	19,76
UHD-KT	12,70
UHE-KT	16,23
UMC-KT	10,46
UMD-KT	12,70
UME-KT	16,23
UTC-KT	10,46
YANT	2,18
YATW	11,86
YAWS	1,59
YBNT	4,93
YBSP	8,16
YBTW	19,76
YCNT	5,92
YCSP	9,89
YCTW	21,73
YCWS	2,76
YDSP	15,81
YDTW	19,76
YDWS	2,96
YENT	7,92
YETW	26,68
YEWS	2,96

			rondelle butée	entretoise	rondelle	écrou	goupille
							
moteurs	type	puissance	(1/pack)	(1/pack)	(2/pack)	(1/pack)	(4/pack)
MERCURY	A	(9,9/15ch)				MANT	
	B	(20/25ch)			MBWS	MBNT	
	C	(30/60ch)	MCTW		MCWS	MCNT	
	D	(60/140ch)	METW		MEWS	MDNT	
	E	(V6/IB)	METW	MESP	MEWS	MDNT	
OMC	A	(9,9/15ch)	OATW	OASP		OANT	APIN
	B	(20/35ch)	OBTW	OBSP		OBNT	APIN
	C	(50/75ch)	OCTW	OCSP		OCNT	EPIN
	D	(75/140ch)	ODTW	OCSP		OCNT	EPIN
	E	(V6/IB)	OETW	OESP		OENT	EPIN
YAMAHA	A	(9,9/15ch)	YATW		YAWS	YANT	APIN
	B	(20/30ch)	YBTW	YBSP		YBNT	APIN
	C	(40/60ch)	YCTW	YCSP	YCWS	YCNT	CPIN
	D	(60/115ch)	YDTW	YDSP	YDWS	YCNT	CPIN
	D	(150/250ch°)	YETW	YDSP	YEWS	YENT	EPIN
E	(inboard)	YETW	YDSP	YEWS	YENT	EPIN	
SUZUKI	A	(9,9/15ch)			SAWS	SANT	APIN
	B	(20/30ch)				SBNT	APIN
	C	(35/50ch)				YENT	EPIN
	D	(60/140ch)				YENT	EPIN
TOHATSU	A	(9,9/15ch)	TATW		TAWS	TANT	APIN
	B	(25/35ch)	TBTW			TBNT	APIN
	C	(40/70ch)	TCTW			TCNT	CPIN
	D	(90/140ch)	TDTW	YDSP	TDWS	TCNT	CPIN
HONDA	E		HETW	HESP			



KITS DE TRANSFORMATION D'HELICES SOLAS AMITA

Groupe	DE	A	réf.
C	Yamaha	Mercury	UMC-KT
	Yamaha	Tohatsu	UTC-KT
D	Yamaha	Mercury	UMD-KT
	Yamaha	Honda	UHD-KT
E	Yamaha	Mercury	UME-KT
	Yamaha	Honda	UHE-KT

O.M.M.

PROPU

OA-A25x1500E	257,34
OA-A25x1750E	281,59
OA-A25x2000E	305,82
OA-A30x1500E	372,05
OA-A30x1750E	415,91
OA-A30x2000E	445,15
OA-A35x1500E	454,99
OA-A35x1750E	505,36
OA-A35x2000E	555,70
OA-A40x1500E	595,22
OA-A40x2000E	729,48
OA-A40x2500E	863,74
OA-A45x1500E	738,43

PYI

PS-02100134	279,72
PS-02112212	425,67
PS-02114200	322,30
PS-0225M112	279,72
PS-0225M134	279,72
PS-0230M134	279,72
PS-0230M200	279,72
PS-0230M214	279,72
PS-0235M200	322,30
PS-0235M212	322,30
PS-0235M214	322,30
PS-0240M212	425,67
PS-0240M234	425,67

CARACTÉRISTIQUES ET AVANTAGES DU JOINT TOURNANT PSS

- Une cale toujours sèche : pas de suintement du tube d'étambot.
- Pas d'entretien
- Economique : pas d'usure de l'arbre et pas de corrosion.
- Made in USA.
- Certifié A.B.S, VERITAS, etc...
- Garantie et SAV dans le monde entier

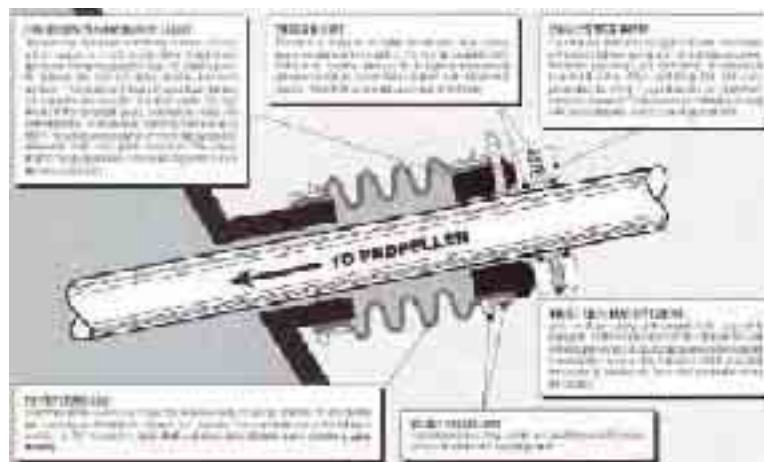

D arbre mm	D arbre pouces	D tube mm	D tube pouces	référence
25		38	1 1/2"	PS-0225M112
25		44,5	1 3/4"	PS-0225M134
25,4	1	44,5	1 3/4"	PS-02100134
30		44,5	1 3/4"	PS-0230M134
30		51	2"	PS-0230M200
30		57	2 1/4"	PS-0230M214
31,75	1 1/4	51	2"	PS-02114200
35		51	2"	PS-0235M200
35		57	2 1/4"	PS-0235M214
35		63,5	2 1/2"	PS-0235M212
38,1	1 1/2	63,5	2 1/2"	PS-02112212
40		63,5	2 1/2"	PS-0240M212
40		70	2 3/4"	PS-0240M234

ARBRES D'HÉLICE

Arbres d'hélice réalisés en inox AISI 316 rect. H8 avec des machines à commande numérique (CNC). Cône au 1/10^{ème}.

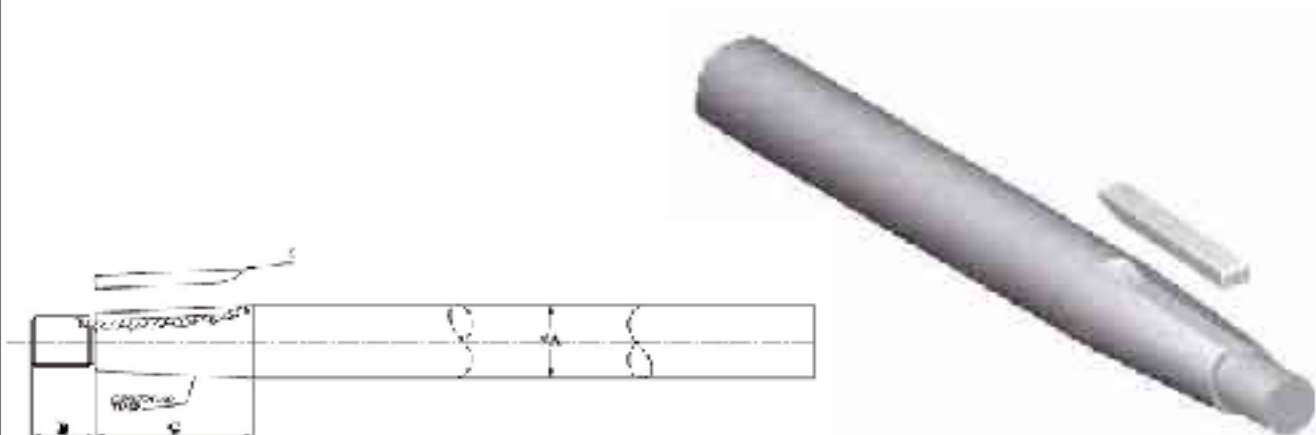

A	B	C	K	kg/m	L1500mm	L1750mm	L2000m	L2500mm
25	25	53	6x6	3.85	OA-A25x1500E	OA-A25x1750E	OA-A25x2000E	
30	30	70	8x7	5.55	OA-A30x1500E	OA-A30x1750E	OA-A30x2000E	
35	35	80	10x8	7.55	OA-A35x1500E	OA-A35x1750E	OA-A35x2000E	
40	35	90	12x8	9.86	OA-A40x1500E		OA-A40x2000E	OA-A40x2500E
45	40	100	14x9	12.48	OA-A45x1500E			

O.M.M.

PROPU

OT-PS-40	420,68
OT-TP-25	111,88
OT-TP-30	126,80
OT-TP-35	147,69
OT-TP-40	183,49
OT-TP-45	222,28
OT-TP-50	275,98
OT-TS-25	216,31
OT-TS-30	223,77
OT-TS-35	296,86
OT-TS-40	296,86

PALIER ARRIÈRE

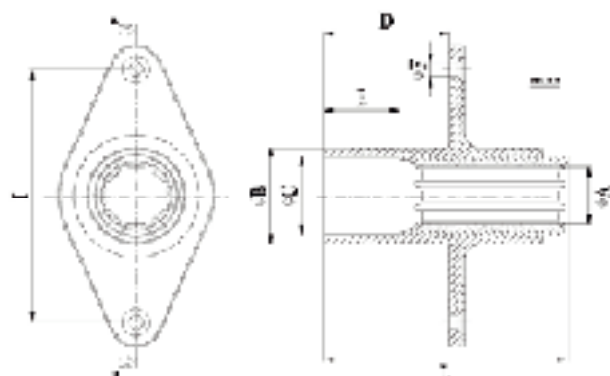

A mm	B mm	C mm	D mm	E mm	F mm	I mm	L mm	référence
25	47	39x1.5	58	38	6.5	110	109	OT-TP-25
30	53	45x1.5	65	38	6.5	120	129	OT-TP-30
35	58	48x1.5	75	46	8.5	150	145	OT-TP-35
40	65	54x1.5	85	46	8.5	155	165	OT-TP-40
45	72	61x2.0	95	50	10.5	160	170	OT-TP-45
50	78	67x2.0	110	50	10.5	160	205	OT-TP-50

PRESSE ÉTOUPES

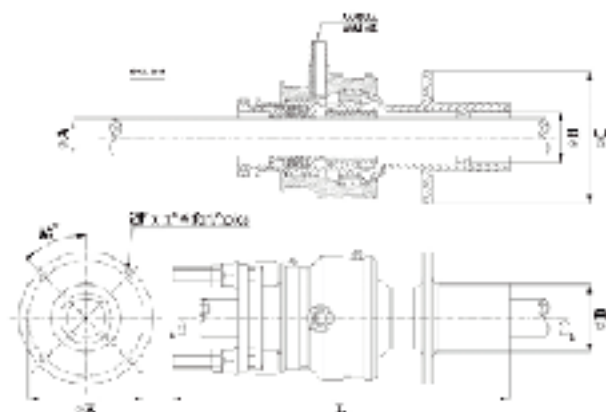

D mm	B mm	C mm	L mm	D mm	E mm	F mm	référence
25	39x1.5	100	230	52	85	9	OT-TS-25
30	45x1.5	100	230	52	85	9	OT-TS-30
35	48x1.5	120	300	61	100	9	OT-TS-35
40	54x1.5	120	300	61	100	9	OT-TS-40

PRESSE ÉTOUPES AVEC EMBASE

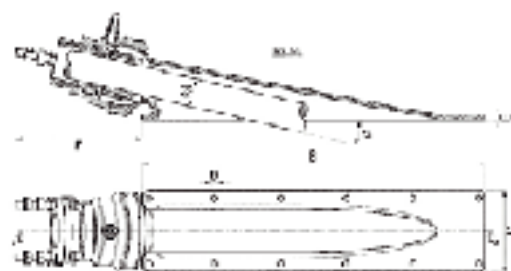

angle	B mm	C mm	D mm	nb trous	E mm	F mm	référence
11 à 16°	450	100	8.5	12	6	185	OT-PS-40

O.M.M.

PROPU

SÉRIE UNIVERSELLE

Ø arbre mm, Ø ext. pouces. en laiton ou résine

φ arbre mm	φ ext. mm	L mm	réf. laiton	réf. résine
20	31.75 = 1"1/4	76.20	CER-52.307.20	
22	31.75 = 1"1/4	76.20	CER-52.307.21	
25	38.10 = 1"1/2	100	CER-52.307.25	CER-52.208.25
30	44.45 = 1"3/4	120	CER-52.307.30	CER-52.208.30
35	47.62 = 1"7/8	140	CER-52.307.35	CER-52.208.35
40	53.97 = 2"1/8	160	CER-52.307.40	CER-52.208.40
45	60.32 = 2"3/8	180	CER-52.307.45	CER-52.208.45
50	66.67 = 2"5/8	200	CER-52.307.50	CER-52.208.50
55	76.20 = 3"	220	CER-52.307.55	
60	82.55 = 3"1/4	240	CER-52.307.60	CER-52.208.60
65	85.72 = 3"3/8	260	CER-52.307.65	
70	95.25 = 3"3/4	280	CER-52.307.70	
75	101.60 = 4"	300	CER-52.307.75	
80	101.60 = 4"	320	CER-52.307.80	
85	114.30 = 4"1/2	340	CER-52.307.85	
90	114.30 = 4"1/2	360	CER-52.307.90	

SÉRIE EUROPE

Ø arbre mm, Ø ext. mm.

D arbre mm	D ext. mm	L mm	référence
25	35	100	OB-25 ALFA/EU
30	40	120	OB-30 BETA/EU
35	48	140	OB-35 DELTA/EU
40	56	160	OB-40 YOTA/EU
45	61	180	OB-45 GAM/EU
50	66	200	OB-50 EPS/EU

SÉRIE US

Ø arbre et Ø ext. pouces.

D arbre mm	D ext. mm	L mm	référence
25.40 = 1"	31.75 = 1"1/4	101.60 = 4"	CER-52.306.00
25.40 = 1"	38.10 = 1"1/2	101.60 = 4"	CER-52.306.01
31.75 = 1"1/4	44.45 = 1"3/4	127.00 = 5"	CER-52.306.02
38.10 = 1"1/2	50.80 = 2"	152.40 = 6"	CER-52.306.03
44.45 = 1"3/4	60.32 = 2"3/8	177.80 = 7"	CER-52.306.04
50.80 = 2"	66.67 = 2"5/8	203.80 = 8"	CER-52.306.05
28.57 = 1"1/8	41.27 = 1"5/8	114.70	CER-52.306.21
34.92 = 1"3/8	47.62 = 1"7/8	139.70	CER-52.306.22
41.27 = 1"5/8	53.97 = 2"1/8	165.70	CER-52.306.23
47.62 = 1"7/8	66.67 = 2"5/8	190.70	CER-52.306.24

TOURTEAUX D'ACCOUPLMENT

Tourteaux d'accouplement en acier C45 et galvanisés.

arbre C mm	E mm	F mm	I mm	H mm	G mm	A mm	D mm	référence
35	102	68	63.50	3	10.5	10.5	82.50	35-FM-102
30	127	68	63.50	3	10.5	10.5	107.95	30-FM-127

AFFECTATIONS PRINCIPALES

moteurs	inverseurs	référence
ZF/HURTH	HBW35/40/50/100/125/150-A-V/250/250A	35-FM-102
VOLVO	M-S-4, HS-1, MS45A, HS63AE	30-FM-127

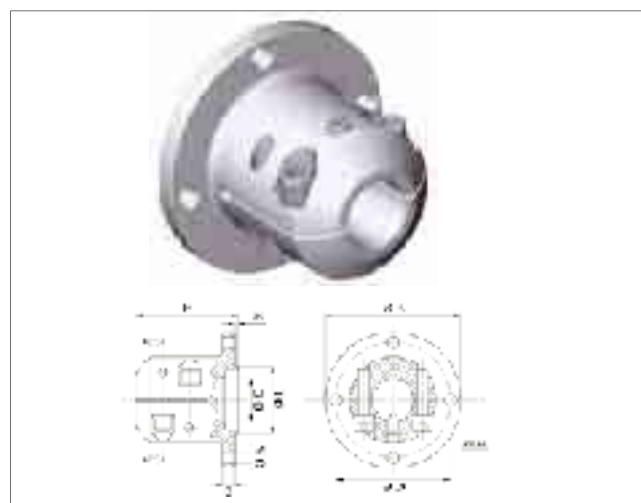
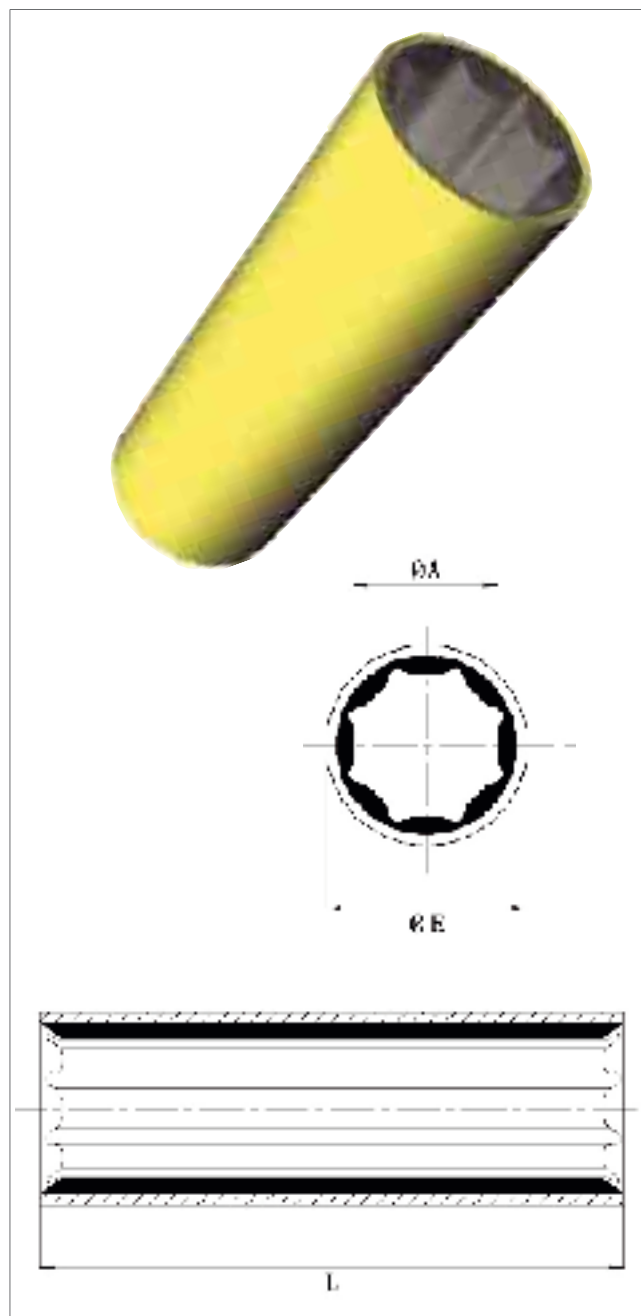

30-FM-127	134,26
35-FM-102	104,42
CER-52.208.25	41,95
CER-52.208.30	47,27
CER-52.208.35	63,02
CER-52.208.40	78,12
CER-52.208.45	100,45
CER-52.208.50	141,80
CER-52.208.60	189,07
CER-52.306.00	47,27
CER-52.306.01	27,13
CER-52.306.02	38,41
CER-52.306.03	51,14
CER-52.306.04	88,63
CER-52.306.05	109,37
CER-52.306.21	39,30
CER-52.306.22	49,89
CER-52.306.23	10,86
CER-52.306.24	182,51
CER-52.307.20	41,36
CER-52.307.21	39,00
CER-52.307.25	27,31
CER-52.307.30	35,45
CER-52.307.35	46,81
CER-52.307.40	60,02
CER-52.307.45	88,37
CER-52.307.50	108,39
CER-52.307.55	180,54
CER-52.307.60	207,45
CER-52.307.65	240,02
CER-52.307.70	296,61
CER-52.307.75	334,16
CER-52.307.80	344,66
CER-52.307.85	488,44
CER-52.307.90	513,38
OB-25-ALFA/EU	32,82
OB-30-BETA/EU	42,53
OB-35-DELTA/EU	58,18
OB-40-YOTA/EU	62,65
OB-45-GAM/EU	81,31
OB-50-EPS/EU	106,68

INSONORISATION

PLAQUES INSONORISATION ISOBEL

En polyester expansé

description	référence
plaque 100 x 200 mm résine ignifugée, avec pelliculage, épaisseur 35 mm	CER-65.099.00

PLAQUES INSONORISATION POLYBEL

Surface aluminium gaufrée, imperméable et thermoréfléchissante + mousse PU + mousse PVC + lame polyuréthane 5 mm

description	référence
dalle 100x145 cm , épaisseur 31 mm, 3.5 kg/m ²	CER-65.100.00

PLAQUES POLYBEL+ FIBRE ALUMINISÉ

Plaques identiques ci-dessus + matelas en fibre de verre aluminisé, épaisseur 6 mm

description	référence
dalle 100 x 150 cm , épaisseur 25 mm, 5 kg/m ²	CER-65.094.00
ruban adhésif 50 m aluminium	CER-65.095.00

ÉTOUPE

En coton/chanvre et téflon de section carrée

emballage	D arbre mm	D mm	référence
2 m	20/25	6	CER-52.190.06
2 m	25/35	8	CER-52.190.08
2 m	40/60	10	CER-52.190.10

TUBES D'ÉTAMBOT

D mm	L standard mm	référence
25	500	OT-TA-25
30	500	OT-TA-30
35	600	OT-TA-35
40	600	OT-TA-40
45	600	OT-TA-45
50	600	OT-TA-50



TARIF 2009

euros

CER

CER-52.190.06	10,14
CER-52.190.08	14,92
CER-52.190.10	20,89
CER-65.094.00	208,77
CER-65.095.00	15,14
CER-65.099.00	62,05
CER-65.100.00	99,53

PROPU

OT-TA-25	89,51
OT-TA-30	104,42
OT-TA-35	119,34
OT-TA-40	134,26
OT-TA-45	156,64
OT-TA-50	182,00